

# HSMx - C660

## Right Angle Surface Mount Chip LEDs



### Data Sheet

#### Description

The HSMx-C660 series of chip-type LEDs are designed to illuminate at a right angle to the direction of mounting. When mounted on a PC board, these devices will emit light in a direction parallel to the board.

The small 3.0 x 2.0 mm footprint of the HSMx-C660 is designed for applications where space is limited. These devices are available in four colors and use untinted, non-diffused optics.

The HSMx-C660 series of parts are compatible with IR reflow soldering process only.

#### Features

- Right Angle Mounting
- Compatible with IR Reflow Soldering Process
- Available in a Wide Variety of Colors
- Available in 8 mm Tape on 178 mm (7") Diameter Reels

#### Applications

- LCD Backlighting
- Keypad Side/Backlighting
- Light Piping
- Right Angle Indicator

#### Package Dimensions

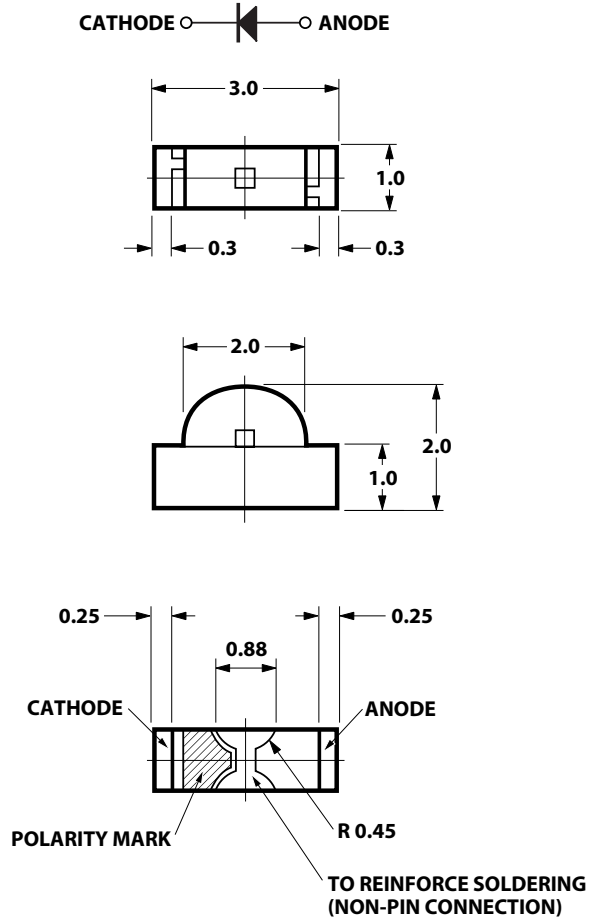

Footprint (mm)	Parts per Reel	DH AS AlGaAs	High Efficiency Red	Yellow	Green
3.0 x 2.0 x 1.0	3000	HSMH-C660	HSMS-C660	HSMY-C660	HSMG-C660

**Absolute Maximum Ratings at T<sub>A</sub> = 25°C**

Parameter	HSMx-C660	Units
DC Forward Current <sup>[1]</sup>	25	mA
Power Dissipation	65	mW
Reverse Voltage (I <sub>R</sub> = 100 μA)	5	V
Operating Temperature Range	-30 to +85	°C
Storage Temperature Range <sup>[2]</sup>	-40 to +100	°C

**Notes:**

1. Derate linearly as shown on Figure 4.

**Optical Characteristics at T<sub>A</sub> = 25°C**

Part No.	Color	Luminous Intensity I <sub>v</sub> (mcd) @ I <sub>F</sub> = 20 mA		Peak Wavelength λ <sub>peak</sub> (nm) Typ.	Color Dominant Wavelength λ <sub>d</sub> <sup>[1]</sup> (nm) Typ.	Viewing Angle 2θ <sup>1/2</sup> (degrees) <sup>[2]</sup> Typ.	Luminous Efficacy η <sub>v</sub> (lm/W)
		Min.	Typ.				
HSMH-C660	DH AlGaAs Red	6.3	16.0	650	639	155	80
HSMS-C660	High Efficiency Red	1.6	5.0	639	626	155	145
HSMY-C660	Yellow	1.6	5.0	589	586	155	500
HSMG-C660	Green	4.0	9.0	570	572	155	595

**Notes:**

1. The luminous intensity I<sub>v</sub> is measured at the peak of the spatial radiation pattern which may not be aligned with the mechanical axis of the LED package.
2. The dominant wavelength, λ<sub>d</sub>, is derived from the CIE Chromaticity Diagram and represents the perceived color of the device.
3. θ<sub>1/2</sub> is the off-axis angle where the luminous intensity is ½ the peak intensity.

**Electrical Characteristics at T<sub>A</sub> = 25°C**

Part No.	Color	Forward Voltage V <sub>F</sub> (Volts) @ I <sub>F</sub> = 20 mA		Reverse Breakdown V <sub>R</sub> (Volts) @ I <sub>R</sub> = 100 μA Min.	Capacitance C (pF) V <sub>F</sub> = 0, f = 1 MHz Typ.	Thermal Resistance Rθ <sub>J-PIN</sub> (°C/W)
		Typ.	Max.			
HSMH-C660	DH AlGaAs Red	1.8	2.2	5	4.5	300
HSMS-C660	High Efficiency Red	1.9	2.6	5	4.0	300
HSMY-C660	Yellow	2.1	2.6	5	3.0	300
HSMG-C660	Green	2.2	2.6	5	8.0	300

**Color Bin Limits (Green)**

Bin ID	Dominant Wavelength (nm)	
	Minimum	Maximum
A	561.5	564.5
B	564.5	567.5
C	567.5	570.5
D	570.5	573.5
E	573.5	576.5

Tolerance :  $\pm 1$ nm**Color Bin Limits (Yellow)**

Bin ID	Dominant Wavelength (nm)	
	Minimum	Maximum
A	582.0	584.5
B	584.5	587.0
C	587.0	589.5
D	589.5	592.0
E	592.0	594.5
F	594.5	597.0

Tolerance :  $\pm 1$ nm**Color Bin Limits (AlGaAs Red)**

Bin ID	Dominant Wavelength (nm)	
	Minimum	Maximum
-	630.0	650.0

Tolerance :  $\pm 1$ nm**Color Bin Limits (High Efficiency Red)**

Bin ID	Dominant Wavelength (nm)	
	Minimum	Maximum
-	615.0	630.0

Tolerance :  $\pm 1$ nm**Light Intensity (Iv) Bin Limits<sup>[1]</sup>**

Bin ID	Intensity (mcd)	
	Minimum	Maximum
A	0.11	0.18
B	0.18	0.29
C	0.29	0.45
D	0.45	0.72
E	0.72	1.10
F	1.10	1.80
G	1.80	2.80
H	2.80	4.50
J	4.50	7.20
K	7.20	11.20
L	11.20	18.00
M	18.00	28.50
N	28.50	45.00
P	45.00	71.50
Q	71.50	112.50
R	112.50	180.00
S	180.00	285.00
T	285.00	450.00

Tolerance :  $\pm 15\%$ **Notes:**

1. Bin categories are established for classification of products. Products may not be available in all categories. Please contact your Avago representative for information on current available bins.

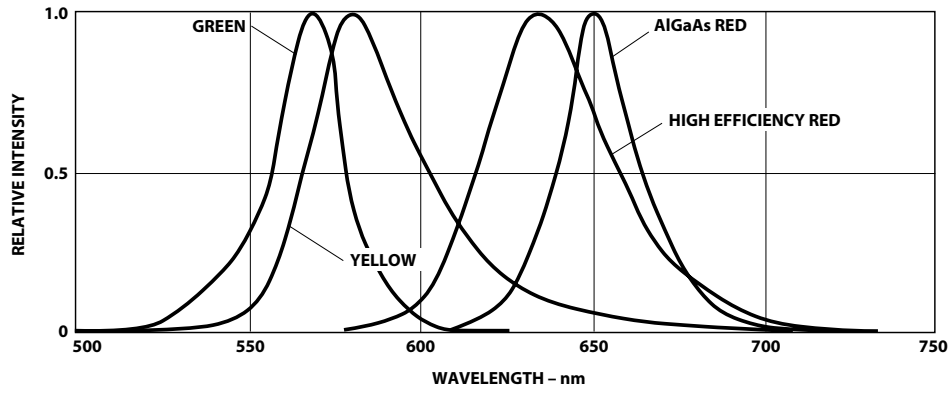

Figure 1. Relative Intensity vs. Wavelength.

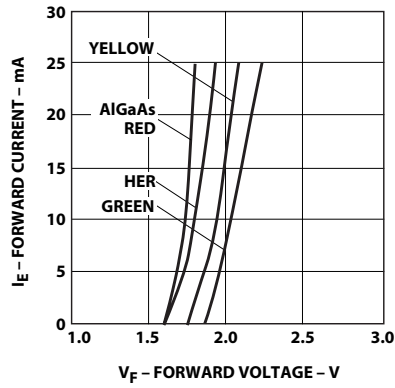

Figure 2. Forward Current vs. Forward Voltage.

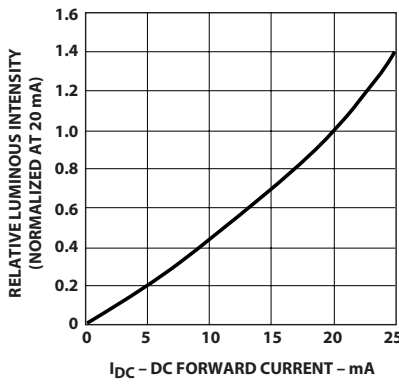

Figure 3. Relative Luminous Intensity vs. DC Forward Current.

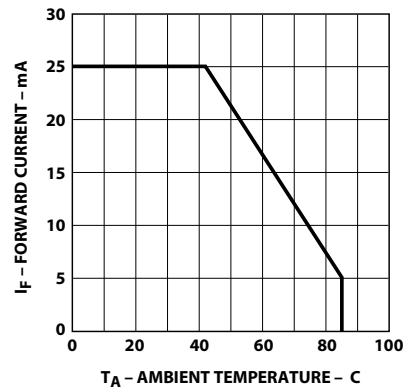

Figure 4. Maximum DC Current vs. Ambient Temperature.

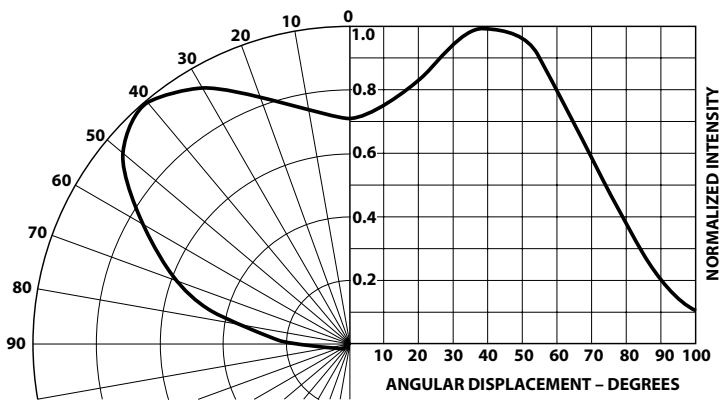
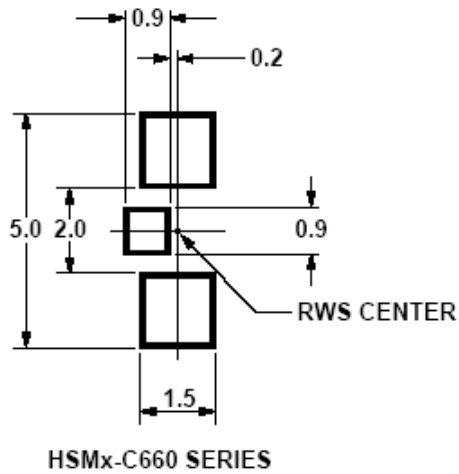

Figure 5. HSMx-C660 Intensity vs. Angle, Vertical Axis.



**Figure 6. Recommended soldering land pattern.**

**Notes:**

1. All dimensions are in millimeters (inches).
2. Tolerance is  $\pm 0.1\text{mm}$  ( $\pm 0.004\text{in.}$ ) unless otherwise specified.

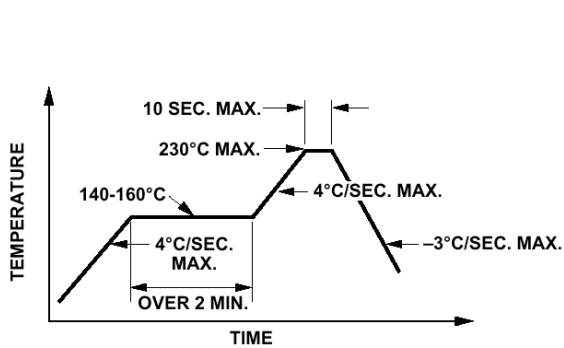
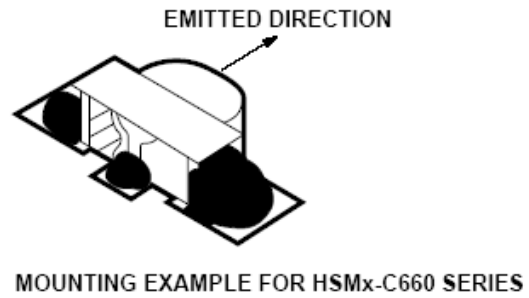

**Figure 7. Recommended reflow soldering profile.**

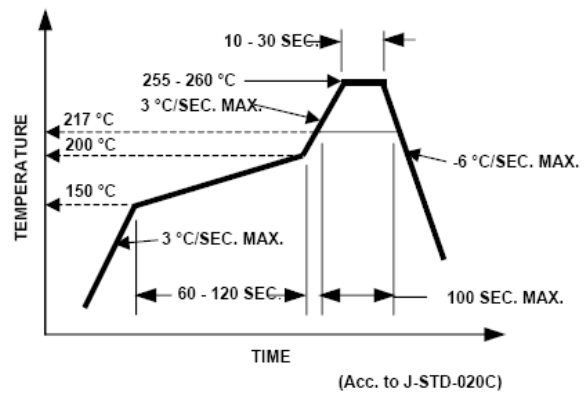

**Figure 8. Recommended Pb-free reflow soldering profile.**

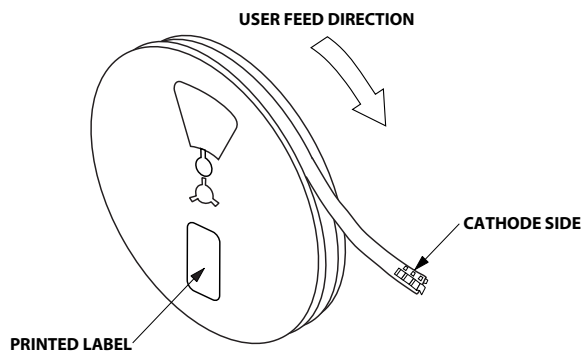

**Figure 9. Reeling Orientation for the HSMx-C660.**



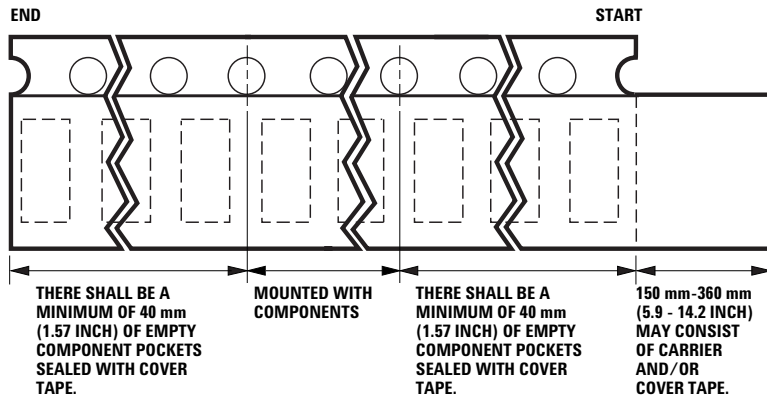

Figure 12. Tape Leader and Trailer Dimensions.

### Reflow Soldering:

For more information on reflow soldering, refer to Application Note AN-1060, Surface Mounting SMT LED Indicator Components.

### Storage Condition:

5 to 30°C @ 60%RH max.

Baking is required before mounting, if:

1. Humidity Indicator Card is > 10% when read at 23 ± 5°C.
2. Device expose to factory conditions <30°C/60%RH more than 672 hours.

Recommended baking condition:

60±5°C for 20 hours.

For product information and a complete list of distributors, please go to our web site: [www.avagotech.com](http://www.avagotech.com)

Avago, Avago Technologies, and the A logo are trademarks of Avago Technologies, Pte. in the United States and other countries. Data subject to change. Copyright © 2006 Avago Technologies Pte. All rights reserved. Obsoletes 5989-0165EN AV01-0118EN -April 24, 2006

**AVAGO**  
TECHNOLOGIES